

PP 18

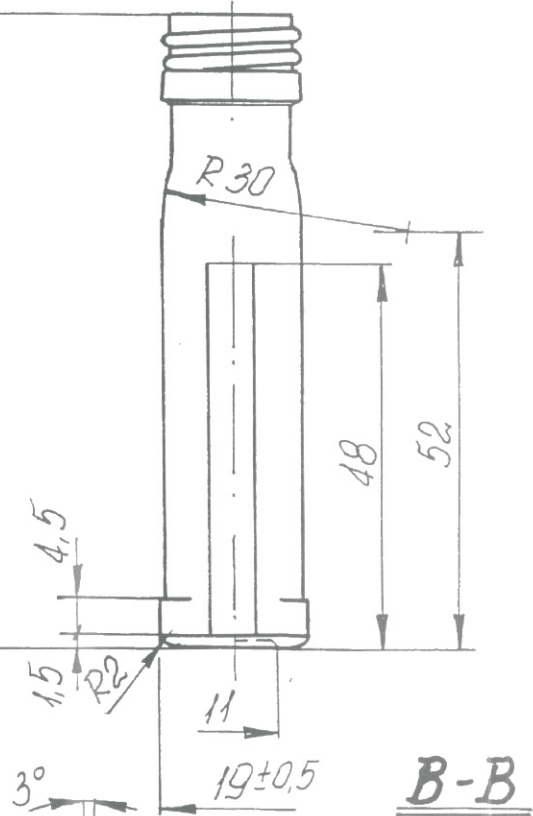

A-A

B-B

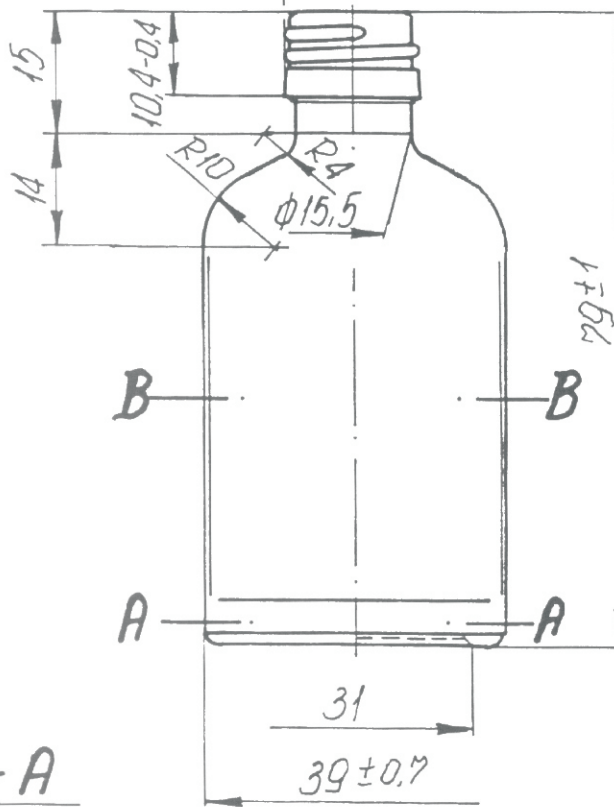
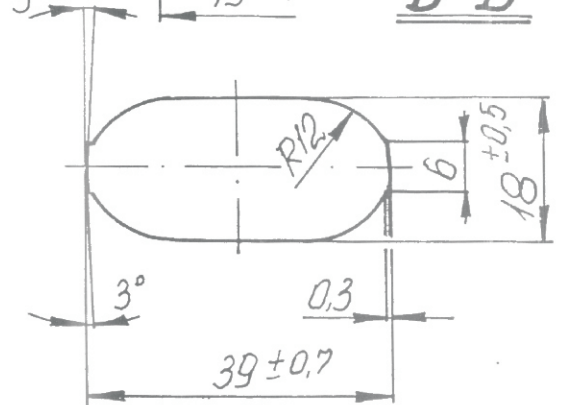
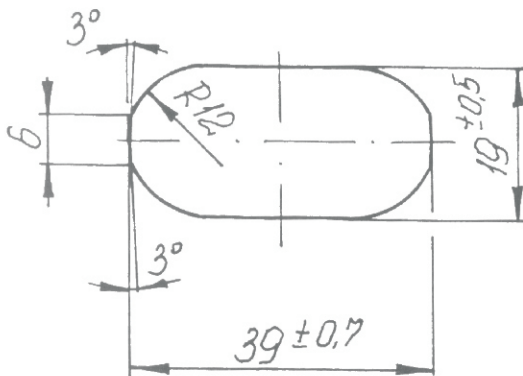

DATE	REVISIONS	CAP. FILLPT.	20 ml.		ADPACK	BOTTLE
05/11/2008		CAP. BRIMF.	22 ± 2 ml.			
		FINISH	PP 18	MOLD No.	548203	Glass - mini
		HEIGHT	79 mm	MACHINE	DG 5 1/2"	
		DIAMETER	39 x 19 mm	DATE	05/11/2008	CAT. No
		WEIGHT	43 g	UNITS PER PALLET		M 0202