

Product: **Pilfer – Proof 30 x 44 mm**
Bottle Neck finish: **DIN 6094-7; GME 305C; GF 305**

Shell Material	
Al Composition	8011
Al Condition	H14
Specific gravity g/cm ³	2.71
Tensile strength Rm MPa	120-160
Elongation. A50, % min	≥ 2
Anisotropy, % max	≤ 2
Material Thickness, mm	0.21 ± 0.01

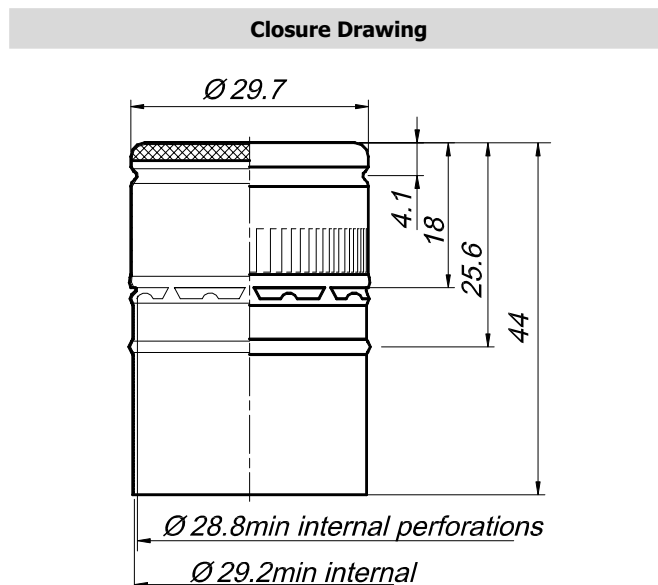

Closure Characteristics	
Outside diameter , mm	Ø 29.7 ± 0.3
Height, mm	44 ± 0.2
Inside diameter, mm	Ø 29.2 min
Weight without liner, g.	3.06 ± 1%
Internal lacquer type	Mod.polyester
External lacquer type	Mod.polyester

Resins obtained from monomers without any phenols or phtalates.

Recommended application details:		
Head pressure force, N		1050-1200
Side roller pressure force, N		80-90
Undertuck roller pressure force, N		90-100
Removal Torque:	Bridges Breaking Torque, N.m.	0.78 – 1.76

NOTE: REMOVAL TORQUES ARE DEPENDANT ON VARIATIONS IN GLASS AND APPLICATION CONDITIONS.

LINER	
Liner material:	Foam (Expanded) Polyethylene (EPE)
Liner thickness, mm	1.8 ± 10%
Liner weight, g	0.27 ± 1%

User has to verify the closures suitability with the specific bottled product and to guarantee the absence of chemical and organoleptic alterations.

Food Contact Approval

All materials intended to come into contact with food are in conformity with the European Community directives, the relevant national regulations and the relevant FDA requirements.

All products comply with Commission directive 94/62/EC concerning heavy metals.

All resins and additives used for inside lacquer production comply with the following Regulations:

- Commission directive 2002/72/ EC of 6 August 2002 relating to plastic materials and articles intended to come into contact with foodstuffs.
- FDA regulation; CFR 21, chapter 175.300 Resinous and polymeric coatings

Packaging specification			
Quantity, pcs.	1 600 pcs	Pallet type – Euro pallet	Dimension 1200 x 800 x*
Box Dimension, mm	600 x 400 x 370 mm	* Height of the pallet may vary with customers' requirements	
Cardboard Type	Corrugated five layer cardboard	Outside packing	Stretch wrapped
Polyethylene Sack	Polyethylene –non-toxic, antistatic		
Adhesive Strip (Scotch)	<100 ppm Pb, Cd, HgCr⁺⁶		
Product Identification	50 mm Labelling	Pallet identification	Labelling

Notes: Closures shall be stored in a well-ventilated place avoiding direct sunlight and strong odour for the period of 1 year. Pallets shall not be stacked.