

Product:		
1.Shell material		
Al composition	8011A	
Al condition	H14	
Tensile strength Rm MPa	110-150	
Elongation. A50, % min	≥ 3	
Anisotropy, % max	≤ 2	
Material thickness, mm	0.19±0,01	
Note : Mechanical values measured after lacquering simulation at 200°C/10 min		
2.Lacquers and inks		
Internal lacquer type	Mod. Epoxy	
External lacquer type	Mod. Polyester/Epoxyester	
External inks type	Alkyd	
3.Liner	Liner dimensions, mm	
	diameter	thickness
EPE	Ø21.7	1.8
Note: Tolerances for liners are +/-0.2mm for thickness and diameter.		
Note: The liner depends on the application or on the customer's requirement.		
4.Recommended application details(Glass) - for PET bottles adjust according to the bottle manufacturers specification:		
Head pressure force, N	550-650	
Thread roller Pressure force, N	80-100	
Undertuck roller pressure force, N	60-100	
Note: These values are starting values and can be varied according to the results to be achieved.		
5. Typical removal torque:		
Bridges Breaking Torque, N.m.	0.44-1.13	
Note: Removal torques depend on the different applications, the type of the bottle neck finish, the quality of the glass etc.		
6.Packaging specification		
Quantity, pcs.	9 500	
Box dimensions-internal, mm	590 x 385 x 350 mm	
Cardboard Type	Corrugated five layer cardboard	
Polyethylene Sack	MDPE–non-toxic, antistatic <100 ppm Pb, Cd, Hg, Cr ⁺⁶	
Adhesive Strip (Scotch)	48 mm	
Product Identification	Labeling	
Pallet type – Euro pallet	Dimensions 1200 x 800 x* * The overall height of the pallet may vary according to the customer's requirements	
Outside packing	Stretch wrapped	
Pallet identification	Labeling	

Pilfer – Proof HSC 22x15

8.Closure drawing: Drawing ID- 22x15_91

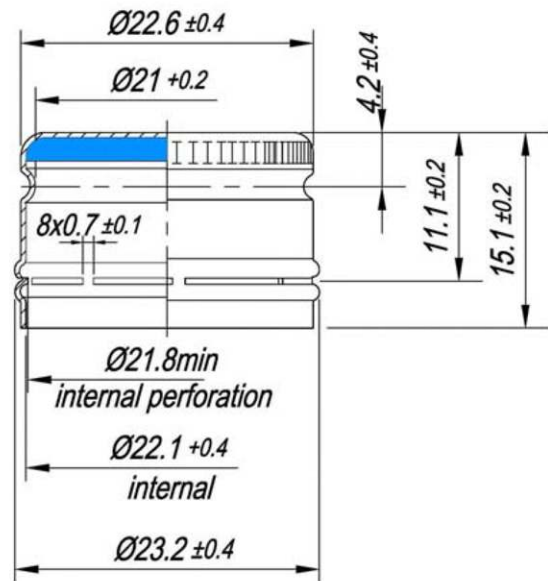

9.Relevant bottle neck finish drawing: 22 Std (CE.T.I.E. GME 30.06)

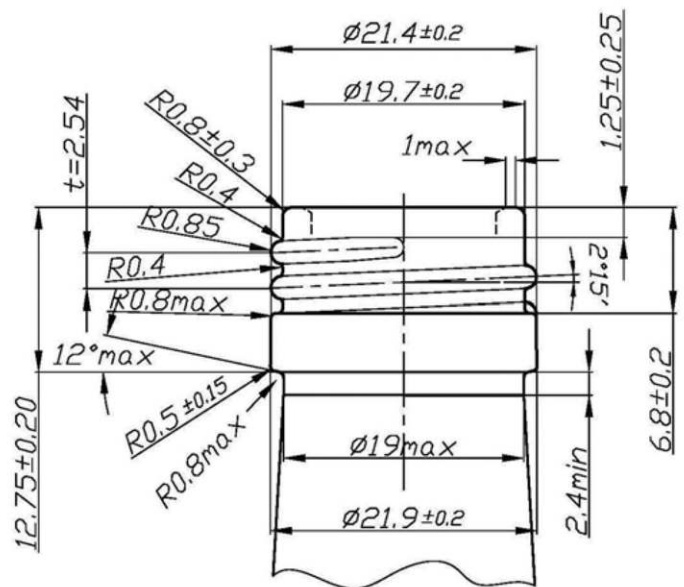

7.Storage and usage

The closures shall be stored in well-ventilated area, away from direct sunlight, strong vapours and odours at temperatures 5°C - 30°C for the period of 1 (one) year after the date of production. The closures should be sold following the principle "first to come-first to go" (FIFO). Pallets should not be double stacked.

